

# DIESEL OXIDATION CATALYSTS

## CATALYTIC CONVERTER TECHNOLOGY

Catalytic converters utilize a precious metal diesel oxidation catalyst bonded to a monolithic, "flow-through" catalyst core. The cores are made either of corrugated, high temperature resistant stainless steel foil or thin-wall cellular ceramics. In both cases, the cores are packaged into rugged stainless steel containers.

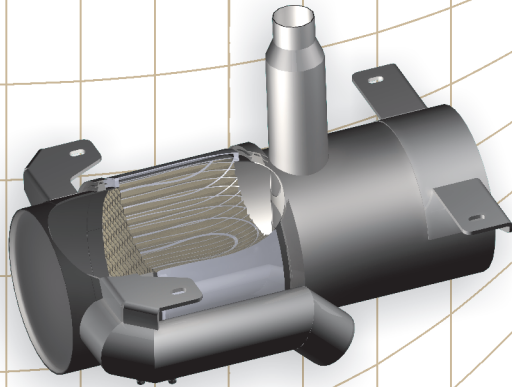

## M-SERIES DIESEL OXIDATION CATALYST

M-Series diesel oxidation catalysts oxidize carbon monoxide, hydrocarbons, and aldehydes contained in diesel exhaust to non-toxic compounds: carbon dioxide and water vapor.

This catalyst formulation provides a 90%+ reduction of carbon monoxide (CO) and an 80%+ reduction of hydrocarbons (HC) in all applications with medium to high exhaust temperatures. The catalyst also oxidizes the soluble organic fraction (SOF) of diesel particulate matter (DPM), resulting in an up to 50% reduction of DPM. The overall conversion of DPM depends upon the engine, exhaust gas temperature, fuel and duty cycle of the equipment.

M-Series catalysts are used on large displacement engines as well as wherever metal substrates are preferred by customers.

## CONVERSION OF DIESEL PARTICULATE MATTER

Conversion of diesel particulate matter is an important function of the modern diesel oxidation catalyst. Conversion of SOF may exceed 80%. Catalysts for heavy-duty applications incorporate sulfate suppressants to maximize their particulate matter performance. Total DPM conversions between 20 and 50% are typically observed. Low sulfur fuel is recommended for high DPM conversions.

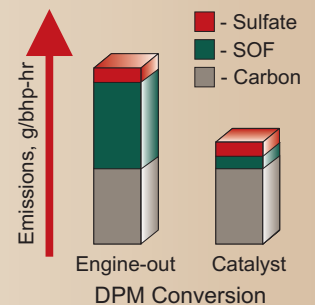

## D-SERIES CATALYSTS

D-Series catalysts are designed to extend the performance of diesel catalytic converters into the low temperature range. Zeolites, also known as molecular sieves, are incorporated into D-Series catalyst washcoats. These zeolites trap and store diesel exhaust hydrocarbons during periods of low exhaust temperature, such as during extended engine idling. Then, when the exhaust temperature increases, the hydrocarbons are released from the washcoat and oxidized on the catalyst.

D-Series catalysts are recommended for the control of HC, DPM and CO in all temperature ranges. The characteristic diesel odor is practically eliminated.

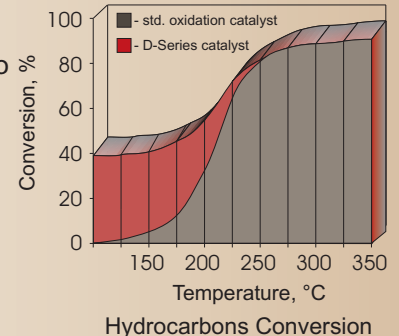

**NETT**  
NETT TECHNOLOGIES INC.  
2-6707 Goreway Drive  
Mississauga, ON L4V 1P7 Canada  
[www.nett.ca](http://www.nett.ca)  
e-mail: [sales@nett.ca](mailto:sales@nett.ca)  
tel: 905.672.5453 fax: 905.672.5949  
toll-free (North America): 800.361.6388

Technical data and information regarding the products described in this brochure is believed to be reliable. However, no representation or warranty is made with respect thereto except as made by Nett® Technologies Inc. in writing at the time of sale. © 2008 Nett® Technologies Inc.

**...the emission control authority.**