



Nett Technologies Inc.

2-6707 Goreway Drive, Mississauga, Ontario

Canada L4V 1P7

tel: 905.672.5453

fax: 905.672.5949

e-mail: sales@nett.ca

web: <http://www.nett.ca>

technical manual

NEES 210™

NEES 220™

**Nett
Emissions
Eliminator
System**



Contents

Product Description	3
Overview	3
Applications.....	3
Principle of Operation	3
Item List & Part Numbers.....	5
Installation Instructions	6
Step 1: Install the Electronic Control Unit (ECU)	6
Step 2: Install the Oxygen Sensor	6
Step 3: Install the Solenoid Valve	7
Step 4: Install the Vacuum Line	7
Step 5: Complete the Electrical Connections	9
Calibration	10
NEES 210/220™ Indicator Lights	10
Fuel System Status Display	10
Oxygen Sensor Display.....	11
Modulation Display.....	11
Setpoint Control and Display.....	11
Fuel System Set up Procedures	11
Idle operation	12
High load operation	12
Medium speed/load conditions.....	12
Troubleshooting.....	13
Controller Test Procedures.....	14



Product Description

Overview

The NEES 210/220™ are digital air-to-fuel (A/F) ratio controllers for gaseous fuelled, carbureted Genset engines with either 12 or 24 Volt electrical systems. The NEES 210/220™ is designed for use with Nett® 3-way catalyst systems in closed-loop configuration. By precisely maintaining the optimal A/F ratio (also known as the stoichiometric A/F ratio) at all engine-operating conditions, the unit maximizes emission reductions in the 3-way catalyst. The controller also reduces fuel consumption and increases engine life.

The controller incorporates an on board diagnostic system, which allows for constant monitoring of its operation and simplifies set-up. The combination of lights built directly into the unit provides an indication of the controller operation without the need for additional monitoring tools. The diagnostic functions include a fuel system status light, and sets of lights to monitor setpoint, Oxygen sensor light, and modulation. The unit also includes an optional, remote-mounted warning light to alert the operator in case of system problems and to prevent the release of excessive emissions.

Applications

The NEES 210/220™ system can control A/F mixtures on carbureted engines fueled by liquefied petroleum gas (LPG, “propane”, “propane-butane”) and by compressed natural gas (CNG).

It is primarily designed to work with air-valve type of gaseous carburetor systems, including IMPCO, Nolff’s, and equivalent products. The controller is also compatible with most venturi-type gaseous carburetors, such as Aisan, Beam, Garretson or Woodward.

The controller is not intended for use on engines with electronic fuel injection systems. Nett® 3-way catalysts can be installed on fuel-injected engines in stoichiometric calibration without the need for modifications or an additional control unit.

Principle of Operation

Figure 1 shows the main functional components of the NEES 210/220™ system, including an electronic control unit (ECU), an oxygen sensor, and a solenoid valve, and their interaction with the vehicle’s fuel and exhaust systems. The oxygen sensor, installed in the vehicle exhaust system upstream of the Nett® 3-way catalytic converter or catalytic muffler, continuously monitors the exhaust gas composition. Lean A/F mixtures produce exhaust gases of high oxygen concentration, while rich A/F mixtures produce exhaust gases with no or little oxygen. A feedback signal from the oxygen sensor is passed to the ECU, which controls the vehicle’s fuel system to maintain the optimal, stoichiometric A/F ratio.

The A/F mixture control is realized by biasing the diaphragm in the fuel regulator using vacuum, which is taken from an area above the throttle in the fuel mixer. This vacuum signal is passed to the fuel regulator through the solenoid valve. ECU-controlled modulation of the valve determines the amount of vacuum signal that can pass to the regulator. The more vacuum is passed to the regulator, the more restricted is the flow of fuel and, consequently, the leaner the A/F mixture.



Since the A/F mixture can be only made leaner (as opposed to richer) by the described control mechanism, it is required that the vehicle's fuel system be calibrated for rich mixture during the set up of the controller. Once installed and set up, as outlined in the set up procedures, the NEES 210/220™ controller leans the mixture, as may be required at different speed and load conditions, to maintain stoichiometric A/F ratio.

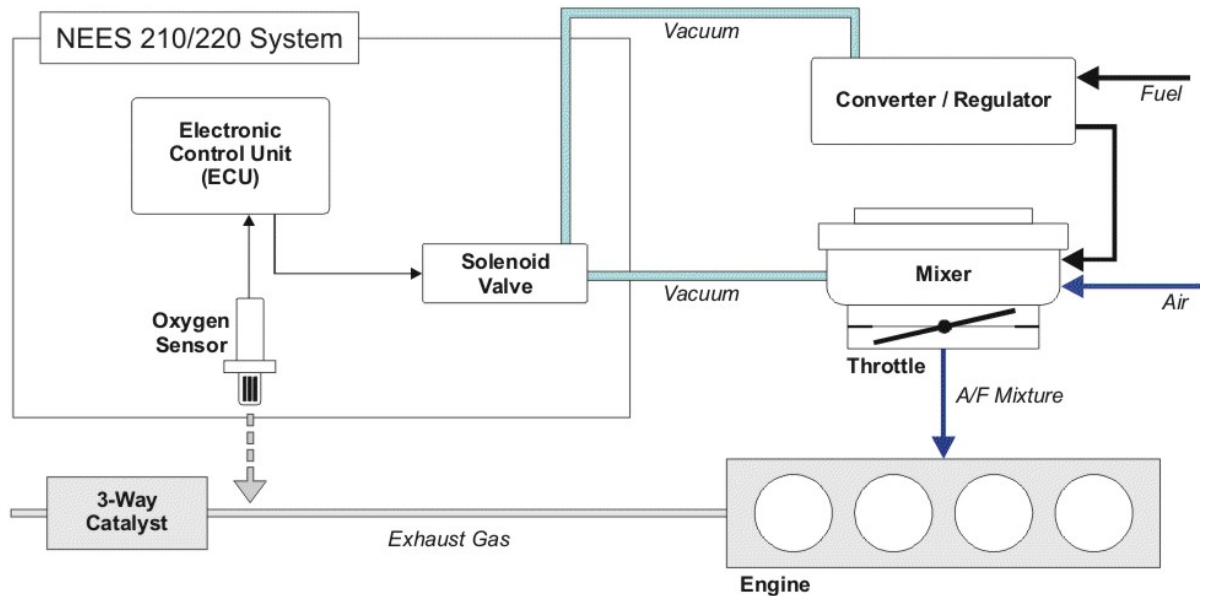

Figure 1. NEES 210/220™ Control System Schematic



Item List & Part Numbers

NEES 210/220™ - Nett Emission Eliminator System, Dynamic Digital Air/Fuel Ratio Controller Assembly for LPG/CNG Engines

NEES 210™ for 12 Volt Electrical Systems
Nett Technologies P/N: AF-00210-KT-NEES2-00010

NEES 220™ for 24 Volt Electrical Systems
Nett Technologies P/N: AF-00220-KT-NEES2-00010

Items included in the NEES 210/220™ kit are listed in the following table.

Item	Description	P/N	Qty
1	NEES 210 Control Module	AF-00210-PT-MODUL-00010	1
	NEES 220 Control Module	AF-00220-PT-MODUL-00010	1
2	Wiring Harness	AF-00200-PT-HRNSS-00010	1
3	Wire Loom (6' Split Loom)	AF-00200-PT-WLOOM-00010	1
4	Spade Connector	AF-00200-PT-WCONN-00010	2
5	Ring Connector	AF-00200-PT-WCONN-00020	1
6	Oxygen Sensor Connector	AF-00200-PT-HRNSS-00020	1
7	Oxygen Sensor	AF-00200-PT-OXSEN-00010	1
8	Solenoid Valve	AF-00200-PT-SOLND-00010	1
9	Clamp, 5/16 (Wiring)	AF-00200-PT-CLAMP-00010	1
10	Clamp, 5/16 (Vacuum Hose)	AF-00200-PT-CLAMP-00020	1
11	Foam Filter	Not Sold Separately	1
12	5/32" Vacuum Line	AF-00200-PT-PHOSE-00156	1
13	Vacuum Elbow (plastic)	AF-00200-PT-FTTNG-00060	1
14	Vacuum Fitting (brass)	AF-00200-PT-FTTNG-00010	1
15	Warning Light	AF-00200-PT-LIGHT-00010	1
16	Check Engine Decal	AF-00200-PT-DECAL-00010	1



Installation Instructions

technical manual

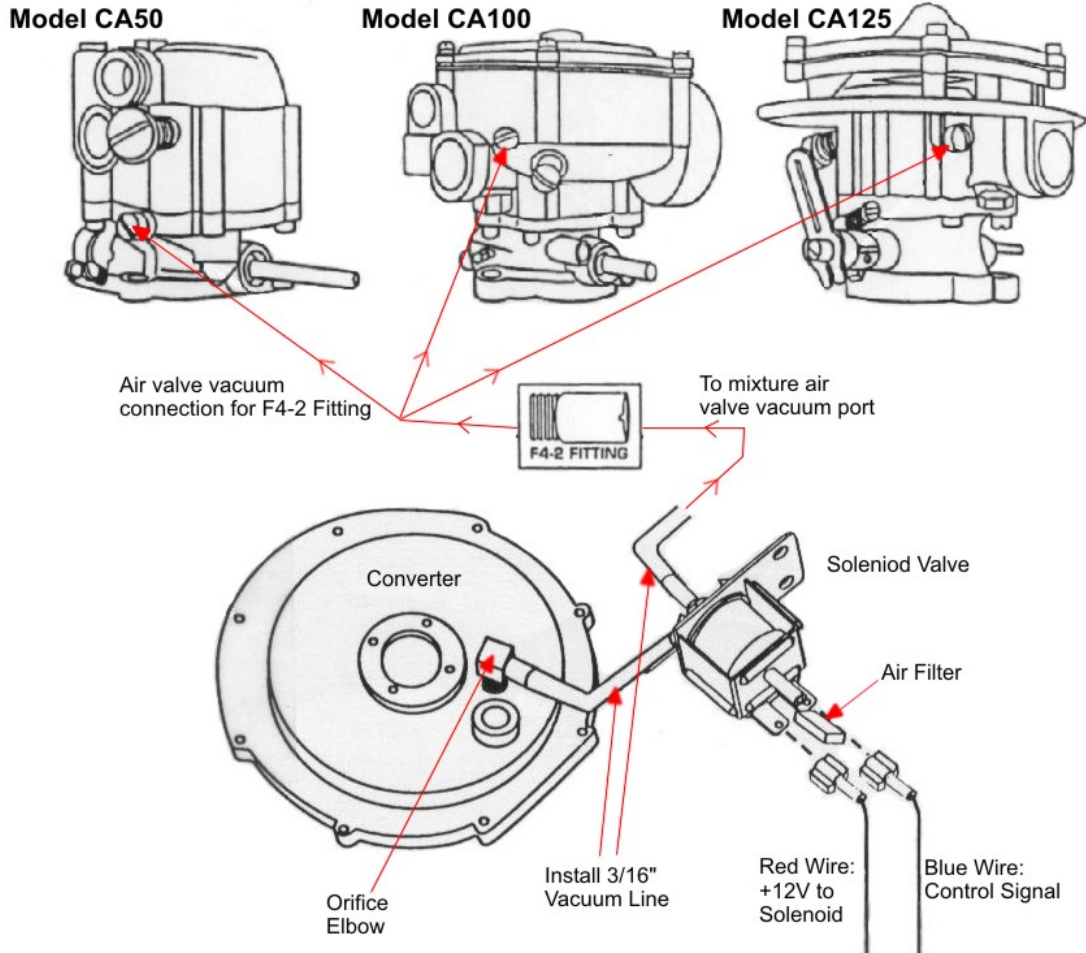

Important: It is strongly recommended that the engine be serviced, and set to manufacturer's specifications prior to the installation of the NEES 210/220™ system. In particular, the intake air and fuel filter elements must be inspected and replaced or cleaned if needed.

Step 1: Install the Electronic Control Unit (ECU)

The unit can be installed in the engine compartment, under the control panel, or on the control panel for operator monitoring. The location should permit the wiring harness to reach the oxygen sensor and the solenoid valve.

Caution: Exposure to high temperatures can damage the ECU. When mounted in the engine compartment, the unit should be installed in a reasonably cool location, preferably at the opposite side of the engine relative to the exhaust manifold and at least 30 cm (12") away from exhaust piping.

Step 2: Install the Oxygen Sensor

The oxygen sensor should be installed into a threaded M18 port in the exhaust pipe or at the inlet to the catalytic converter/muffler. All Nett® 3-Way catalytic



converter/mufflers come with an oxygen sensor port located in the inlet section of the muffler.

Caution: Exposure to high temperatures can damage the oxygen sensor or shorten its life. When mounted in the exhaust pipe, the unit should be placed at least 25 cm (10") away from the exhaust manifold.

Step 3: Install the Solenoid Valve

Secure the solenoid valve to the converter/regulator cover using one of the converter cover screws.

Install the foam filter on the air port of the solenoid valve (it is the brass port of the solenoid located in the proximity to the electrical connections, as shown in Figure 2). Making sure that the port opening is not blocked, place a drop of adhesive on the brass port and place the foam filter over the port.

Step 4: Install the Vacuum Line

This step involves (1) the installation of the vacuum elbow into the fuel regulator, (2) connecting the elbow with the solenoid valve, (3) installing the vacuum fitting in the mixer and (4) connecting the solenoid valve with the mixer vacuum. Solenoid valve ports are referenced in Figure 2.

- (1) Locate the atmospheric vent on the regulator. It may be necessary to modify the vent opening to accept the 1/8 N.P.T. black elbow fitting. Position the vacuum elbow so that the orifice is aimed downward to allow moisture which may accumulate in the line to drain. Note: Do not over-tighten (to avoid breaking the plastic thread).
- (2) Cut sufficient length of the flexible vacuum hose and connect the vacuum elbow with the plastic vacuum port on the side of the solenoid valve (see Figure 2).
- (3) Identify a vacuum port in the mixer and install the vacuum fitting.

Air Valve Mixers: These mixers have a predrilled port to access the air valve vacuum. This port is located in the area between the throttle and the mixer air valve. It is usually plugged by a small, chromium-plated screw. Remove the screw and install the included brass vacuum fitting.

Venturi mixers: Most venturi-type mixers have no predrilled vacuum ports. In such case, the mixer has to be drilled and tapped before the vacuum fitting can be installed. If possible, venturi vacuum should be used by drilling into the mixer just underneath the venturi nozzle. Alternatively, the vacuum can be taken from the mixer throat at any place between the venturi and the throttle. Using a 7/32" drill bit, drill a hole into the venturi adjacent to the casting boss (right hand side). Tap the hole to 1/4" x 28 thread pitch and install brass fitting supplied. Note: See Woodward Addendum.

Important: The source of vacuum must be from a point above the engine throttle. The controller works properly at vacuums between about 1 – 3 kPa (4 – 12" H₂O). Connecting the NEES 210/220™ to engine manifold vacuum (i.e. below the throttle plate) will result in unstable operation and may result in serious loss of fuel control including shutdown.

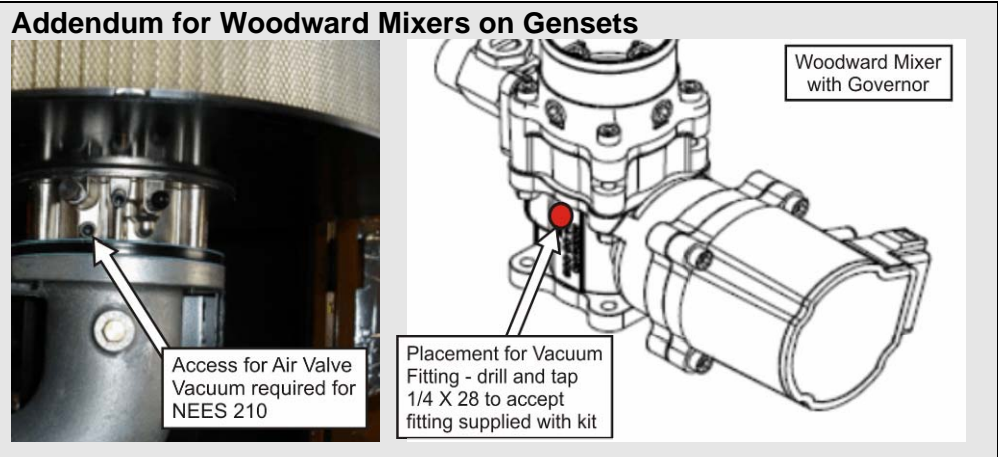

Cut sufficient length of the flexible vacuum hose and connect the vacuum fitting in the mixer with the remaining plastic vacuum port of the solenoid valve (see Figure 2).

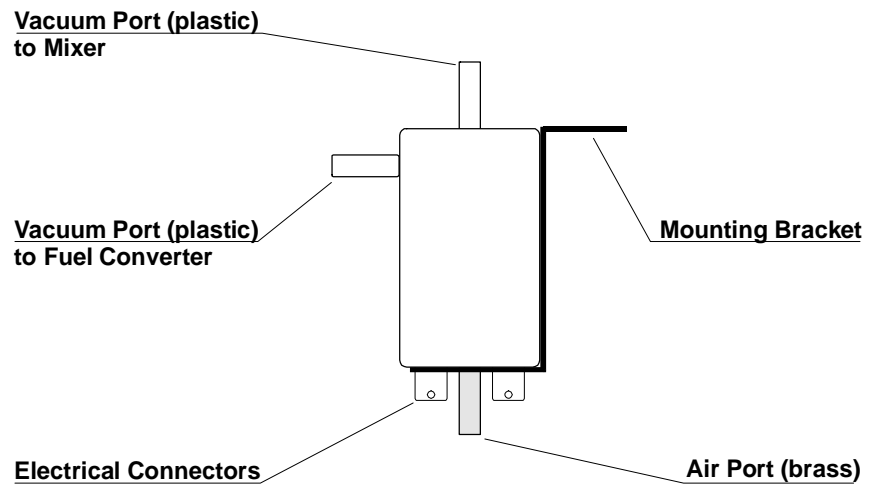

Figure 2. Solenoid Valve Ports



Step 5: Complete the Electrical Connections

Once installed, the unit must be wired into the electrical system following the diagram below.

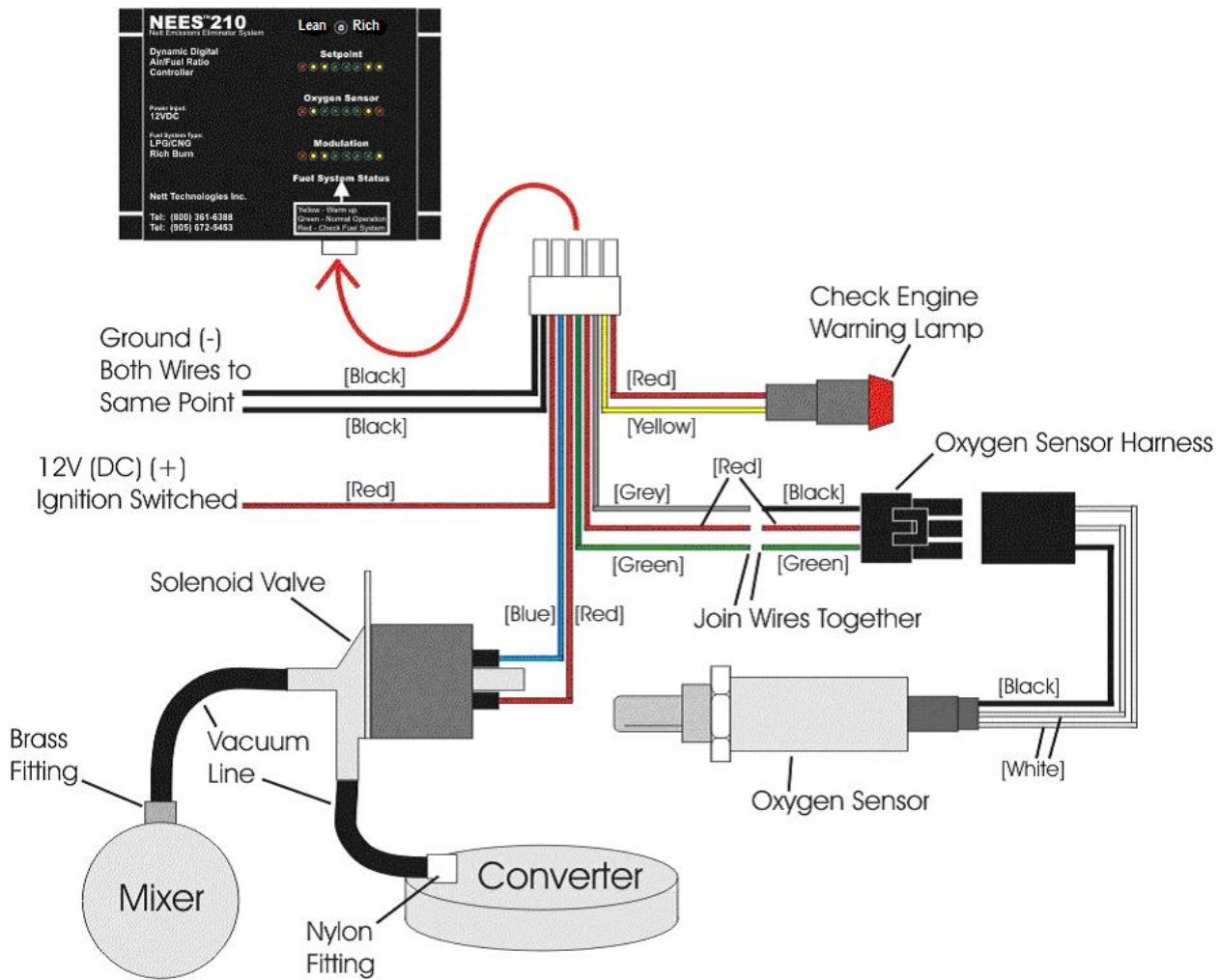

Figure 3. Electrical Connection Schematic

All electrical connections should be soldered and sealed. It is important to adequately pre-heat wires before applying solder. Cold solder joints may cause improper operation of the controller.

NEES 210/220™ Indicator Lights

The NEES 210/220™ electronic control unit is equipped with indicator lights, as illustrated in Figure 4. The lights allow for the initial calibration of the system, as well as and for servicing and monitoring the engine operation throughout the life of the unit.

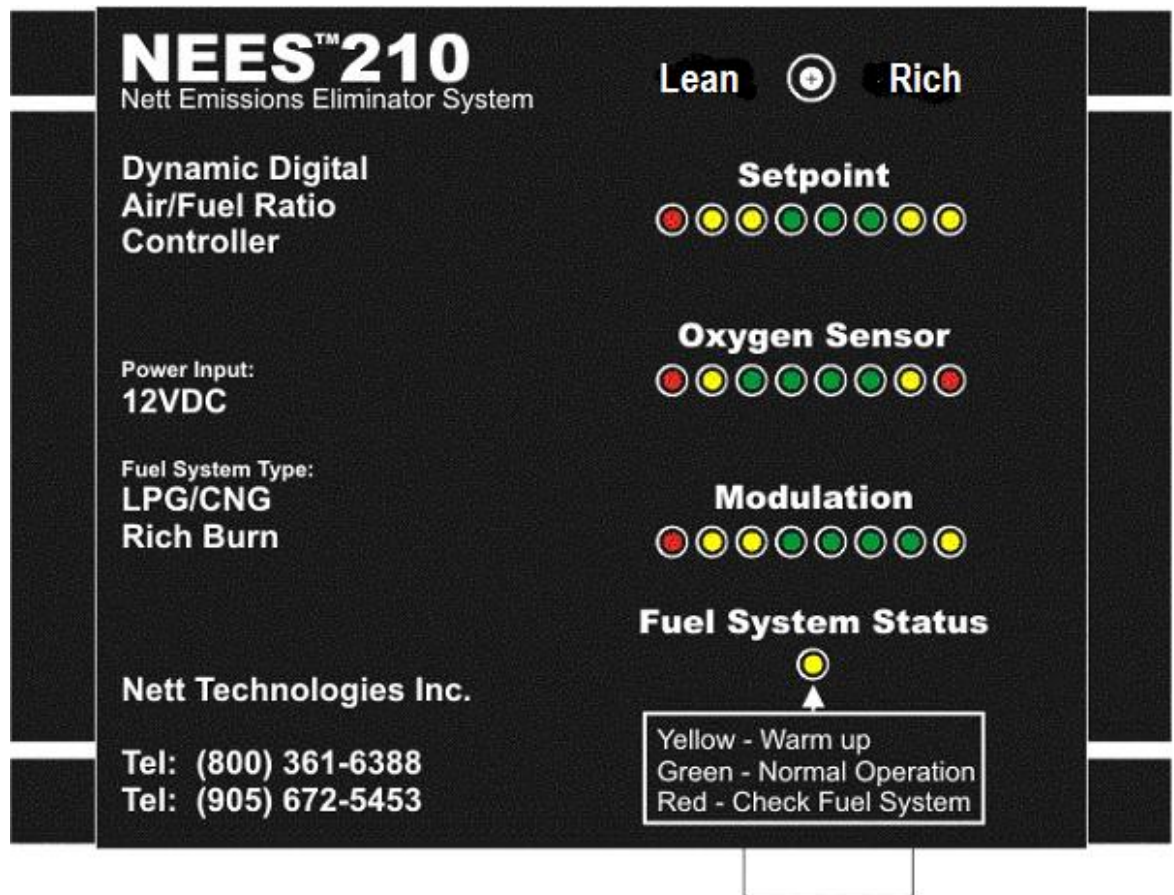

Figure 4. NEES 210/220™ Indicator Lights

Fuel System Status Display

This yellow color light illuminates on start-up, indicating that power is being supplied to the unit. After approximately 40 seconds the light turns green. If the controller is unable to maintain proper mixtures, the light will turn red and stay on indicating that engine maintenance and/or service is required. The failure light is triggered when the controller is unable to bring the Air-Fuel mixture to stoichiometric for a period lasting longer than 2 minutes. It also lights the external lamp, Nett PN AF-00200-PT-LIGHT-00010 if installed. If the problem is corrected the light will become green.



Oxygen Sensor Display

This display shows the output from the Oxygen Sensor mounted upstream of the catalyst. Under normal operating conditions this display will oscillate back and forth rapidly. Oxygen Sensors deteriorate with use, and this display gives the maintenance technician information as to the sensor's condition. If the display is to the left the engine is lean, and to the right the engine is rich.

Modulation Display

The display indicates the modulation percentage of the solenoid valve. In fact, the NEES 210/220™ pulses the solenoid between “on” and “off” many times per second. The modulation percentage is a measure of the average voltage of this pulsating valve and an indication of the amount of control the solenoid is exerting over the A/F mixture. Higher modulation value indicates that the valve is “more open” and more vacuum is passed to the fuel regulator in order to lean the A/F mixture.

It is normal for these lights to oscillate indicating changing modulation, as required to control the A/F mixture. Typically, modulation oscillates in the green area of the display, however it may change due to changing conditions, such as worn mixers, dirty air and/or fuel filters, etc. The frequency of oscillation should be about 0.5 – 1 cycle per second.

Steady modulation at either end-value indicates that the unit is unable to properly control the A/F mixture. For example, if the display is at the right this indicates that the maximum amount of vacuum is being passed to the fuel regulator in an attempt to correct a rich condition. In a controllable system, this action should lean the mixture causing the modulation to decrease. However, if the system is not responding and the rich condition continues, the controller will remain in its 100% modulation state indefinitely.

Setpoint Control and Display

The Setpoint Control (the small screw control at the top of the controller between the words “Rich” and “Lean”) has the ability to adjust the mixture from below stoichiometric to above stoichiometric using a 1/8” slot head screwdriver. There is an 8 lamp bar graph display that indicates the relative control position to the installer. The bar graph indicates a richer setting as it moves to the right, leaner as it moves to the left. The left hand two lamps are yellow, and if the controller is adjusted in this range the engine will be below stoichiometric, causing the engine to lose power from lack of fuel. The next three lamps are green, indicating at or slightly above stoichiometric (as they illuminate to the right). This is the range where the controller should be normally set at. To the right of the green lamps are two yellow and one red lamp. If the controller needs to be set in this range it is possible that the CNG/LPG mixer needs to be adjusted to a leaner base mixture.

Fuel System Set up Procedures

Since the controller can only lean A/F mixture by restricting the flow of fuel in the regulator, it is necessary to adjust the engine's fuel system to a rich condition after the installation of the NEES 210/220™ system. It is then the task of the controller to lean the mixture as may be required at different engine speed and load conditions or during transients.

The set up of the controller must be performed with the engine at proper operating temperature and at a high speed “Load” condition. While holding the engine speed



and load, adjust the power valve to attain proper oscillation of the Modulation Display. See calibration tip below. At the same time, ensure that the modulation lights are in the green. If the display lights are within these guidelines the system is properly set up and no further adjustments are required.

Calibration Tip: In a properly calibrated system, the mixture oscillates between rich and lean at a frequency of about 0.5 – 1 cycle per second, as indicated by the oxygen sensor and solenoid modulation displays in the NEES 210/220™ unit.

In practice, there are three adjustment mechanisms, addressing the A/F mixture at different speed/load conditions, as follows.

Idle operation

A/F mixture composition at idling is controlled by the idle *air bypass adjustment screw*, which is located on the body of the mixer.

Note: Some venturi systems cannot be controlled at stoichiometric during idle due to insufficient venturi vacuum at low engine speed. This is usually acceptable, as idle emissions constitute a small percentage of the total engine emissions.

High load operation

A/F ratio during high load operation is controlled by the *power adjustment screw*, which is located at the fuel inlet to the mixer.

Medium speed/load conditions

The A/F ratios at intermediate load conditions are determined in air-valve mixers by the valve shape. For best results, *mixers and/or air valves designated as “feedback” should be used with A/F mixture controllers*. Consult your fuel system supplier for part numbers.

Venturi mixers do not have a medium load mixture adjustment.



Troubleshooting

The following troubleshooting chart lists some possible problems related to the operation of the A/F mixture control system. Further tests may be required to diagnose catalytic converter problems using an appropriate exhaust gas analyzer.

Problem	Possible Cause	Action
Engine hesitation or fluctuation in engine speed.	Vacuum signal is too strong. The controller has been connected to engine manifold vacuum (i.e., vacuum from underneath the throttle).	Connect the controller to air valve or venturi vacuum (i.e., vacuum from above the throttle).
	The vacuum connection is correct, but the signal is still too strong for the vehicle's fuel system.	Vacuum elbow installed in the atmospheric vent of the propane converter has a predrilled orifice (hole) of 1.5 mm (0.060") diameter. Remove the elbow and enlarge the orifice by drilling to a 1.8 mm (0.070") diameter. Reinstall the elbow.
Rich condition. The Modulation display is to the far right.	Dirty intake air cleaner element.	Remove the air cleaner and run the engine. If the A/F mixture returns to normal, replace the air cleaner element.
	Vacuum leaks into converter.	Verify that vacuum hoses are properly connected. Repair or reconnect hoses, as needed.
	Vacuum hose between the solenoid and converter has been incorrectly connected to the liquid side of the converter.	(Diagnosis: the engine quits when the solenoid to converter hose is removed.) Install the vacuum hose in the atmospheric vent port on the vapour side of the converter.
	Faulty mixer, or regulator, or solenoid valve.	Create a controlled vacuum leak into the mixer. If the oxygen light starts pulsing green/red, check the mixer, regulator, and verify that the solenoid valve is working.
	Faulty oxygen sensor.	Check the oxygen sensor signal (between the green and black wires) using a voltmeter. The voltage should be cycling between 0 and 1 V. If the voltage doesn't cycle, install new oxygen sensor and re-test.
	Faulty electronic control unit.	Replace the controller.



Problem	Possible Cause	Action
Lean condition. The Modulation Display is to the left.	Dirty fuel filter.	Check and replace the fuel filter.
	Vacuum leaks into mixer.	Check vacuum hoses and connections.
	Mixer is not adjusted rich.	Create a rich condition by blocking the intake air cleaner or by injecting propane into a mixer vacuum port. If the A/F mixture returns to normal, adjust the mixer for rich mixture using its power and idle screws. If necessary, replace the standard lean valve by a feedback valve in the air valve mixer.
	Insufficient fuelling rate due to a mixer or converter/regulator problem.	Check the mixer and converter for proper operation. Fix or replace, as needed. You may also try using a lower pressure spring in the fuel regulator (e.g., replace the standard blue-coded spring with the orange spring in IMPCO mixers).
	Oxygen sensor problem	Check exhaust gas piping upstream of the sensor for air leaks, repair if necessary. Connect voltmeter to the oxygen sensor (green-black wire) and create a rich condition. If the oxygen sensor remains lean, replace it and re-test.
Faulty electronic control unit.	Replace the controller.	

Controller Test Procedures

Caution: Do not use a test light. Check voltages with a Digital or Analog multimeter. Make measurements with positive lead of meter, negative lead of meter to be attached to controller ground.

- 1) With key in the on position is there 12 (or 24 if a 24 Volt system) volts to the controller? If not check the power wiring, otherwise go to step 2.
- 2) Check that the connection of the controller ground is good. Wire should be run to battery or main engine ground. If the ground is good go to step 3.
- 3) Is there 12 volts (or 24 if this is a 24 Volt system) to the red wire on the fuel control valve solenoid (PN AF-00200-PT-SOLND-00010)? If yes go to step 4.
- 4) If the engine starts and then quits disconnect the vacuum hose at the converter. Restart the engine. If it runs properly check the plastic vent elbow (PN AF-00200-PT-FTTNG-00060) and make sure that the opening is not blocked. The vent hole should be between 0.060 and 0.080 inch diameter. If this does not fix the problem go to step 5.
- 5) Check the fuel control valve solenoid (PN AF-00200-PT-SOLND-00010) by blowing through the port that connects to the converter. Air should come out of the



port that the foam filter is attached to only. Apply 12 volts to the valve; plug the filter port and blow through the valve. Air should come out of the port that goes to the mixer vacuum. If the fuel control valve checks out then go to step 6.

6) If Oxygen Sensor Display and the Modulation Display are both to the left when running richen the mixture. If the display then moves to the right this indicates that the oxygen sensor is working. Check to see why the engine is running rich (i.e. Plugged air filter, primary fuel pressure in the converter is too high, dirty air valve assembly in the mixer, idle or power valve set too rich). If there is still a problem with the system go to step 7.

7) If the Oxygen Sensor Display on the controller is yellow when running, induce more fuel and check if the light turns red. If so the oxygen sensor is working. Check to see why the engine is running lean (i.e. vacuum leak at intake manifold, PCV valve stuck open, exhaust leak before the oxygen sensor such as a blown exhaust manifold gasket, fuel tank installed incorrectly so that engine is running off vapor instead of liquid. If there is still a problem go to step 8.

8) When the engine is set up and running correctly the voltage at the blue wire on the fuel control valve will vary between 4 and 10 volts.

When the engine is set up and running correctly the voltage at the green wire from the O2 sensor should vary between 0.1 to 0.9 volts.

Nett Technologies Inc. has a corporate policy of continuous product development. Specifications are subject to change without notice.